

# LEVITON BRAND PIR LIGHT SWITCH

**WARNING!! THIS CIRCUIT WAS MEANT TO CONNECT TO 117 VOLT AC POWER. IT IS DANGEROUS. IF YOU DONT KNOW WHAT YOU ARE DOING - DON'T MESS WITH IT!!**

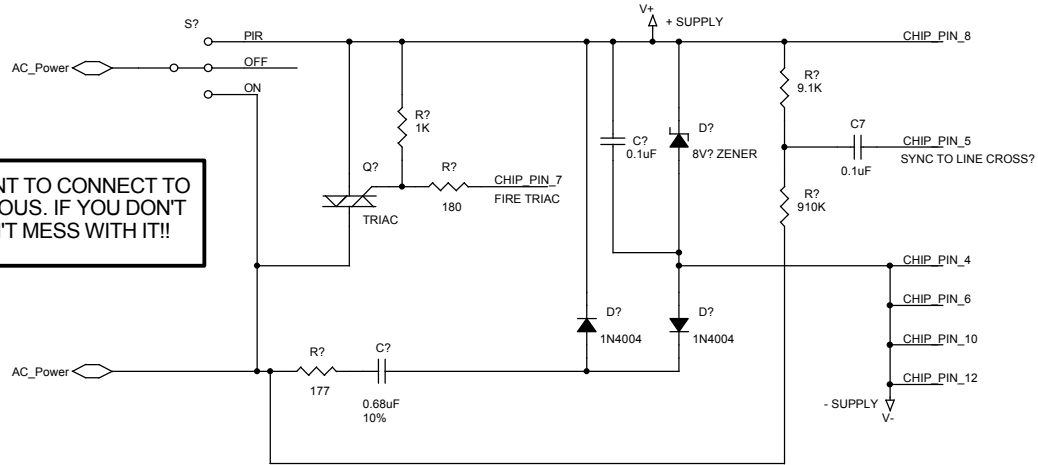

THE "CHIP" REFERRED TO HERE IS A 16 PIN DIP THAT CONTAINS MUCH OF THE CIRCUITRY.

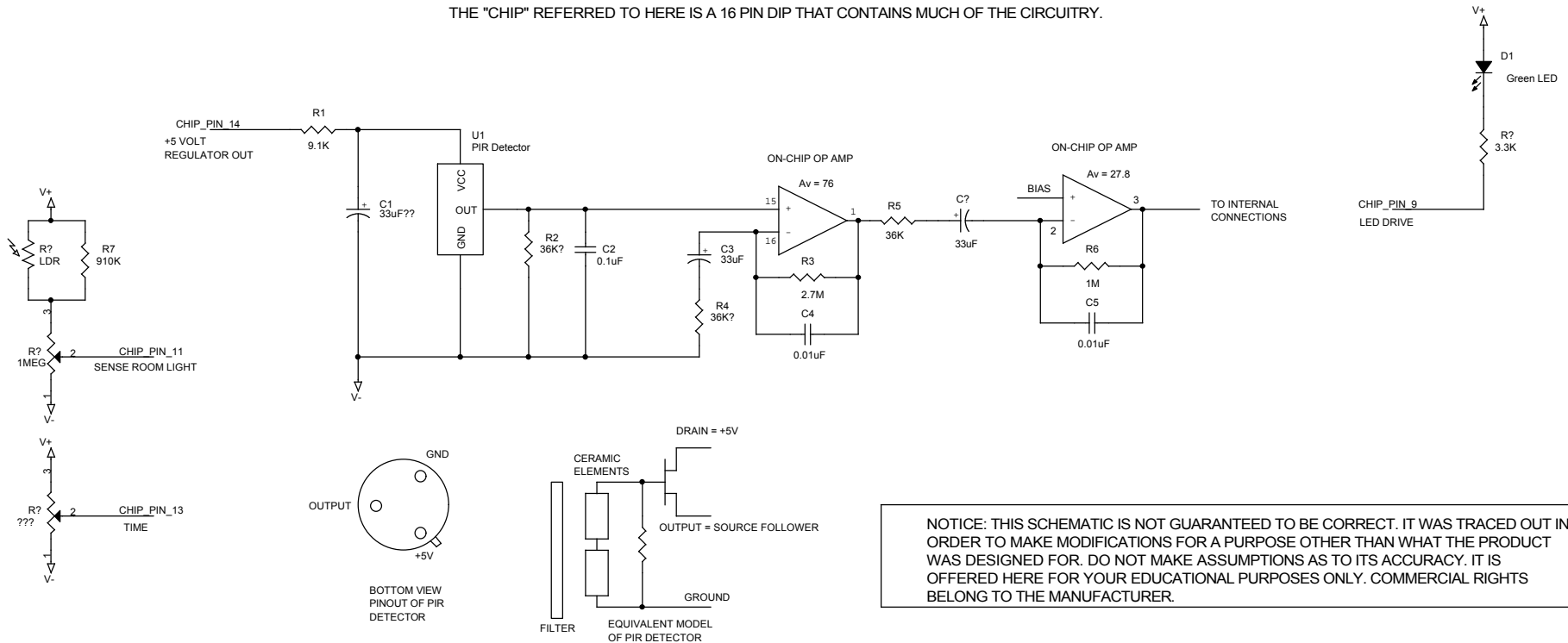

**NOTICE: THIS SCHEMATIC IS NOT GUARANTEED TO BE CORRECT. IT WAS TRACED OUT IN ORDER TO MAKE MODIFICATIONS FOR A PURPOSE OTHER THAN WHAT THE PRODUCT WAS DESIGNED FOR. DO NOT MAKE ASSUMPTIONS AS TO ITS ACCURACY. IT IS OFFERED HERE FOR YOUR EDUCATIONAL PURPOSES ONLY. COMMERCIAL RIGHTS BELONG TO THE MANUFACTURER.**